

Technical Data Sheet

Shower Systems



No.	Description	Code	Fixings Included
1	Marine Black Bar Valve System	TR3018	YES



Inlet Pressure	Flow Rate (l/min)
1bar	7.60
2bar	10.60
3bar	12.60
4bar	15.15
5bar	18.50

Flow from valve may vary depending on accessories and domestic supply.

Dimensions - TR3018

Diagrams not to scale. All dimensions in mm (tolerance of +/-5mm)

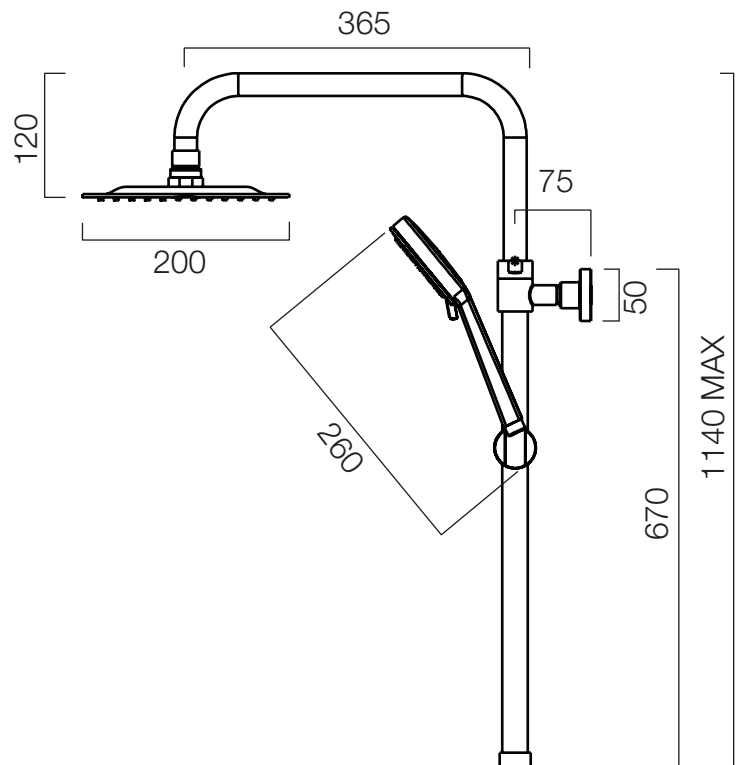
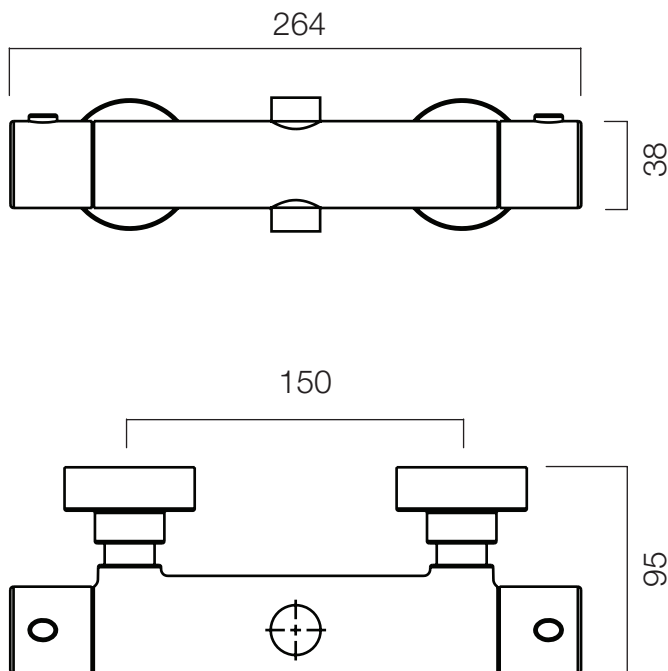

FAQs

How tall is the riser rail? Adjustable: 760mm - 1140mm

How long is the shower hose? 1.5m

What is the recommended minimum pressure for optimum performance of valve? 1.0bar

What is the valve connection size? 1/2" BSP

What materials are the handles made from? ABS