

Twistloc[®]

INSTALLATION GUIDE



Twistloc® HOW TO INSTALL

CUT

Use only purpose designed pipe cutters and cut the pipe squarely. Ensure the pipe and fitting are both free from burrs and scratches and they are kept free from dirt or debris.

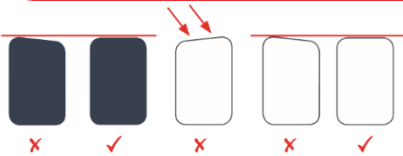

When cutting pipe, ensure that the ends are cut square and are free of burrs.

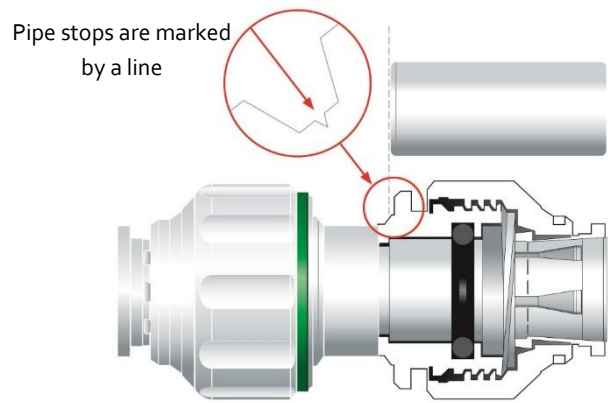

LOCK

Ensure the pipe is pushed into the fitting fully past both the collet (gripper) and the O-Ring, and is engaged properly. Twist the screw cap until the green coloured ring is no longer visible; this confirms a proper, secure fit and locks the pipe into position. It also increases pressure on the O-Ring seal around

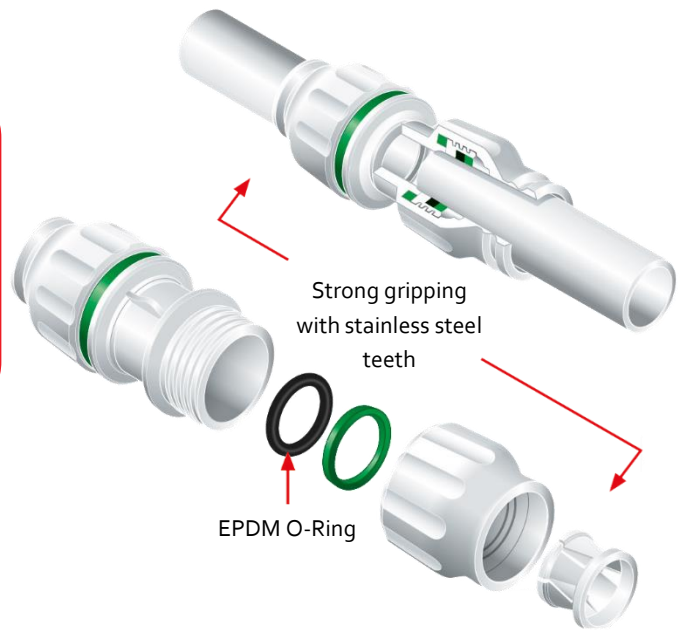
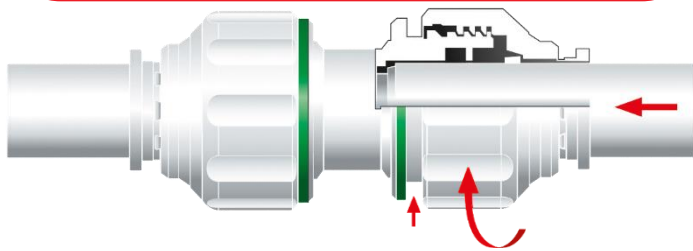

CHECK

Pull to check connection is secure. We recommend pressure testing the system before use. A pipe insert should be used to act as an internal support.

Ensure there are no scratches, gouges or any other

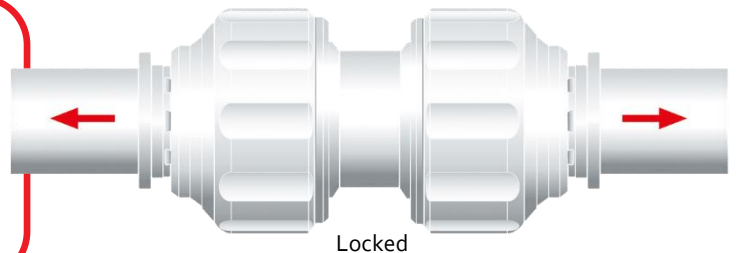

SEPARATE

Before attempting to disconnect any fitting, make sure that the system is de-pressurised. Unlock the fitting by twisting until the green ring is fully visible. Press collets squarely against the face of the fitting, with collets depressed, pull on the pipe to remove it

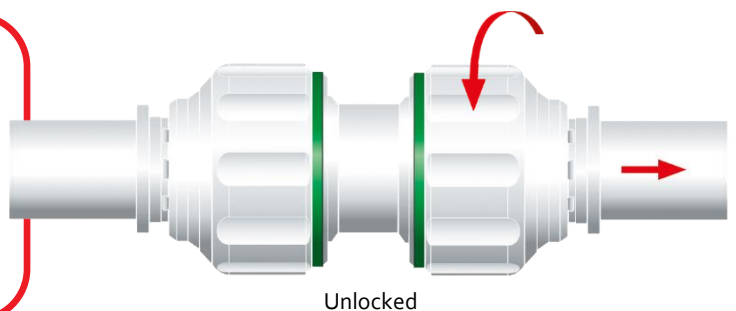

Twistloc® PIPE CUTTING

Pipe stops/insertion depths are located at the following distances for the fitting end.

Twistloc Black Products

Size	Pipe Stop Depth
15mm	29.3mm
22mm	34.3mm
28mm	38.5mm

Twistloc White Products

Size	Pipe Stop Depth
10mm	22mm
15mm	33mm (Union Connector is 39mm)
22mm	36mm
28mm	42mm

All Twistloc fittings will be delivered in the unlocked position. This is evident by the green ring located between the screwcap and the body being visible.

Ensure that all pipe and fittings are free from scores and scratch marks and kept free from dirt and debris prior to installation.

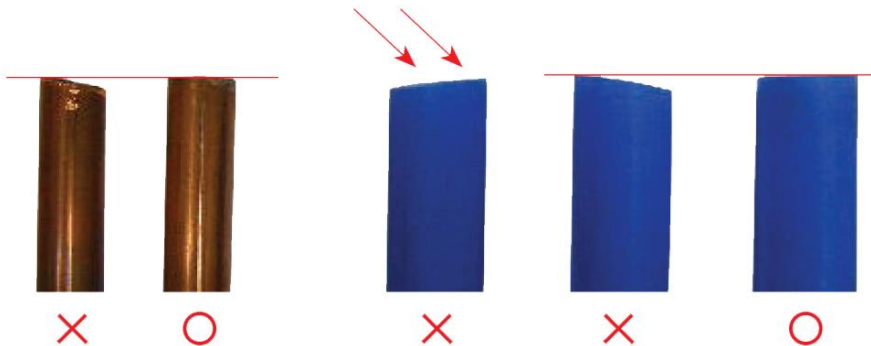

When cutting tube, ensure that the ends are cut squarely and free of burrs.

Twistloc® CONNECTIONS

CONNECTING TO COPPER PIPE

- Twistloc fittings are designed for use on metric copper pipe which conforms to BS EN 1057-R520
- When installing with copper pipe cut the pipe with an appropriate pipe cutter designed for use with copper pipe.
- Pipe ends should be inspected carefully and remove all burrs or swarf
- Push the pipe firmly into the fitting until the pipe passes both the collets (gripper) and the 'O' ring and is engaged properly.
- Twist the screw cap until the green coloured ring is no longer visible. This locks the collet in place and at the same time increases the pressure on the O ring seal around the pipe for greater security.

CONNECTING TO A COMPRESSION FITTING

Compression fittings which comply with BS EN 1254 are suitable for use with Twistloc pipe.

- Using the Twistloc pipe cutters cut the pipe squarely and insert the Twistloc pipe insert.
- If required apply PTFE Tape to the pipe
- Fully insert the pipe into the fitting
- Tighten the compression nut. Do not overtighten as this can compress the pipe too much
- Oil based jointing compounds are not suitable for use with Twistloc pipe
- A Twistloc pipe insert must always be used with Twistloc pipe
- Copper olives should be used rather than brass
- After tightening Twistloc pipe will not rotate in a compression fitting.

CONNECTING NEAR A SOLDERED JOINT

Soldering work should always be carried out before Twistloc fittings are installed. If this is not possible you must observe the following precautions.

- Don't allow flux to come into contact with Twistloc pipe or fittings. Do not use excessive amounts of Flux, as Flux runs can occur inside the pipe during soldering. Only apply Flux to the copper pipe end only.
- Solder must not come into contact with Twistloc
- Twistloc pipe and fittings can become excessively hot with soldering taking place nearby. To minimise the effects of this the copper pipe should be wrapped in a damp cloth. This should minimise any likely heat transfer.
- Systems should be flushed with water to remove any internal Flux residues.
- If any plastic pipework or fittings have been damaged during the soldering process they should be replaced immediately.
- Soldering must not take place within 450mm of a Twistloc fitting. Any residual flux must not come into contact with Twistloc products.

CONNECTING TO OTHER BRANDS OF PIPE

Twistloc insist on rigorous testing to ensure that all of our pipes and fittings are manufactured within certain tolerances. As we are unable to guarantee those tolerances used by other manufacturers, we are unable to recommend that Twistloc products be used with pipe or fittings produced by any other manufacturer.

CONNECTING TO CHROME PLATED OR STAINLESS STEEL PIPE

Due to the relative surface hardness of these materials Twistloc fittings cannot be connected directly to chrome plated or stainless steel pipe.

CONNECTION TO BOILERS

Twistloc fittings and valves should never be connected directly to a boiler

Although most modern boilers have a high limit thermostat, residual heat can be conducted by the heat exchanger. Therefore, Twistloc recommend a minimum of 1 metre from the boiler casing should be run in copper pipe unless otherwise stated in the boiler manufacturer's installation literature.

A gravity primary circuit operating on an uncontrolled cooking range or solid fuel boiler should then be an entirely in copper and the heating circuit run in copper for the first metre.

Refer to BS5955: Part 8 for further clarification.

All appliances should have safety devices to make sure they cannot operate above the working temperature and pressure range. If safety devices are not incorporated within the appliance then external controls will be needed. Water meters (and other devices) can contain check valves that prevent the expansion of heated water back down the main supply from a combi-boiler. If plastic pipe is to be used, a suitable expansion vessel must be fitted. This is especially important to consider if a water meter is fitted retrospectively. Twistloc do not recommend the use of plastic pipe on the main supply between a water meter and a combi boiler if an expansion vessel is not fitted. Twistloc products should not be fitted to a sealed system, oil boiler, a back fired boiler or other uncontrolled heat source.

CONNECTING TO MAINS WATER SUPPLY

A stop tap should be used when connecting to a mains water supply.

CONNECTING TO APPLIANCES

Twistloc manufacture a number of installations for connecting to appliances such as washing machines, dishwashers and even small bore water filters. Pipe clipping distances should always be adhered to when installing valves.

Twistloc® WHERE TO USE

Twistloc has been designed for use in most domestic and commercial hot & cold water and heating applications. Installation work should be carried out using good plumbing practice as outlined in the installation guide.

Twistloc should NOT be used in the following applications:

- Carrying gas, compressed air or fuel oil
- Direct sunlight and ultra violet light. We recommend that if pipework and fittings are used externally that they are either covered or painted to avoid direct UV exposure.
- Areas contaminated with petroleum and oil derivatives
- The conveyance of water with a high concentration of chlorine. This can sometimes be found in swimming pools, hot tubs or decorative water features.
- In a solar heating system as a primary circuit. Temperatures cannot be thermostatically controlled.
- Twistloc should not be installed in a continuously operated re-circulating systems (secondary hot water circulation/ring main installations)

CABLING THROUGH JOISTS

The introduction of plastic pipe and fittings allows pipe to be easily curved and cabled through drilled joists or I-beams. This offers the plumber the following benefits:

- Floorboards can be laid allowing the plumber to work from below before the ceiling is installed
- Fewer chances of piercing the pipe when nailing floorboards into place.

DRILLING THROUGH THE JOISTS

- Drilled holes in joists should be large enough to allow for thermal movement of pipe.
- Hole diameters should be no greater than 0.25 of the depth of the joist and should be drilled on the neutral axis.
- The minimum distance between a hole and a notch in the same joist should not be less than 100mm.
- They should be not less than 3 diameters (centre to centre) apart and should be located between 0.25 and 0.4 times the span from the support.
- For engineered joists, piping can be properly installed through holes in the web section without damaging flange members even when the preformed holes do not align on the plan.

Twistloc® SITEWORK

PIPE SUPPORT

For surface mounted pipe

To allow for expansion you must allow for a minimum of 60mm of pipework, before fitting pipe clips. To reduce side-load or stress on the fittings, pipes should be adequately supported.

Pipe Diameter (mm)	Horizontal Runs (mtr)	Vertical
10mm	0.3	0.5
15mm	0.3	0.5
22mm	0.5	0.8
25mm	0.8	1.0

BEND RADIUS

For sharp bends, standard elbow fittings can be used. For slight bends it is possible to use the flexibility of the pipe to produce a bend which can be clipped into shape, or tighter still with a 15mm cold forming bend, subject to the following limits.

Pipe size	10/15/22/28mm
Min Radius with Clips	100/75/225/300mm
Min Radius with Cold Forming Bend	90mm



CONCEALED PIPEWORK

When installing the Twistloc system in concrete and masonry the pipe should be run in conduit pipe with access boxes for the fittings so that all pipe can be removable for replacement and maintenance therefore complying with the requirements of the Water regulations.

PIPES THROUGH WALLS AND FLOORS

To protect Twistloc pipe and fittings, always sleeve in conduit when passing through walls and floors.

Do not use expanding foam in its initial wet state as the chemicals in the foam can cause a chemical reaction.

To reduce noise and to act as a fire stop the annular gap between the pipe and the conduit should be filled with a resilient material.

It is also suggested that pipework should be run in a conduit when laying it next to metalwork. This will protect the pipe from any sharp edges due to thermal movement.

BURYING PIPEWORK IN SCREED, CONCRETE FLOORS OR WALLS

The Water Byelaws state that distribution pipework must be accessible to facilitate its removal after replacement. Pipework must therefore be placed in conduit before being buried. To prevent against frost, we also recommend insulating the pipework.

TWISTLOC FOR USE IN TIMBER AND STEEL FRAMED BUILDINGS

Twistloc is ideal for use in these applications. It is important during the installation process to ensure that the structural integrity of the vapour layer or the property itself is not compromised. Pipework should be installed in the inside of any thermal insulation.

If the architect did not allow for a recess to allow this to happen, conduit must be used.

METAL TAPE

Where pipework is in or behind wall surfaces and would otherwise not be detected by a metal detector or similar equipment, a metallic tape should be applied to the pipework.

Do not attach tape directly to Twistloc pipe and fittings.

CONNECTING TO A STORAGE VESSEL

We offer a range of tank connectors for connection to cold water storage tanks in 15mm, 22mm and 28mm.

When installing do not use any jointing compound on the connector. Hand tightening is all that is needed. Further mechanical tightening will damage the fitting.

CONNECTING TO BOILERS AND HEATERS

- A minimum length of 1mtr of copper pipe must be installed before connecting to a Twistloc pipework system.
- All connections should be made in accordance with the requirements of BS5955 part 8.
- To avoid serious overheating trapped air must be purged from the heating system before the boiler is operated.
- Always refer to the boiler manufacturers' installation instructions.

TWISTLOC WITHIN INTERNAL DRYWALL SYSTEMS

One of the benefits of Twistloc is that it can easily be cabled within wall structures during the construction process. This is best seen when using 10mm pipe and elbows as a feed to radiators. By incorporating this method, the appearance of pipework on show in the home can be significantly reduced.

CONTINUOUSLY OPERATED RE-CIRCULATING SYSTEMS (SECONDARY HOT WATER CIRCULATION / RING MAIN INSTALLATIONS)

A continuously operated re-circulating system is a water-replenished circulating system which is maintained at a constant high temperature to provide a constant source of hot water. Continuously operated re-circulating systems are used to distribute constant hot water to draw off points that may be distant from the source or hot water storage vessel. Continuously operated re-circulating systems are very different from conventional hot water supply and central heating systems found in domestic properties, for which our products have been tested to, under either BS7291 2010 Class S or WRAS approval standards, and for this reason Twistloc products must not be used on any continuously operated re-circulating systems as they are not approved under the current version of these standards.

FREEZING FOR MAINTENANCE/SYSTEM MODIFICATION

Twistloc pipe can be frozen for maintenance/repairs without damage to the system. When freezing equipment manufacturers' instructions should be followed. Always freeze at a reasonable distance from where pipe is to be cut.

PAINTING TWISTLOC PIPE AND FITTINGS

Twistloc can be painted with either a water-based paint or an oil-based paint with an undercoat. Cellulose based paints, paint strippers, thinners, flux, acid based descalents or aggressive cleaning products must not be used.

ANTIFREEZE

For further advice on anti-freezes, chemical flushing agents and inhibitor treatments, please contact the treatment manufacturer directly.

ELECTRICAL SAFETY

Please contact a registered electrical contractor or your local Electrical Authority with regards to bonding, continuity and electrical safety.

Twistloc[®] PRECAUTIONS

INSULATING PIPE

When installing pipe in an unheated area or outside insulation is required in accordance with BS6700 and BS5422 to protect from frost damage. These requirements are the same as for copper pipe.

UV PROTECTION

Twistloc is suitable for use outdoors however it should either be painted or covered with insulation to protect against exposure to UV rays.

PRESSURE TESTING

It is essential that a full system check takes place upon completion of an installation. Before carrying out any test you must ensure that all Twistloc pipe and fittings are installed correctly.

We suggest a test of 2bar for 10minutes followed by 10bar for 10minutes. Any products that are not manufactured by Twistloc and are unable to withstand the test pressures should be disconnected during the test and capped off using the Twistloc end stop cap.

Pressure testing is NOT a substitute for making sure pipe and fittings are correctly installed. For details on how to make a good joint please refer to the beginning of the installation guide.

ADVISORY SERVICE

For all technical enquiries please complete the [contact form](#) or call 01623 836814

TENSILE STRENGTH TEST

The graph above shows the results of a strength test conducted independently by a Government laboratory. It clearly shows how Twistloc outperforms its competitors.

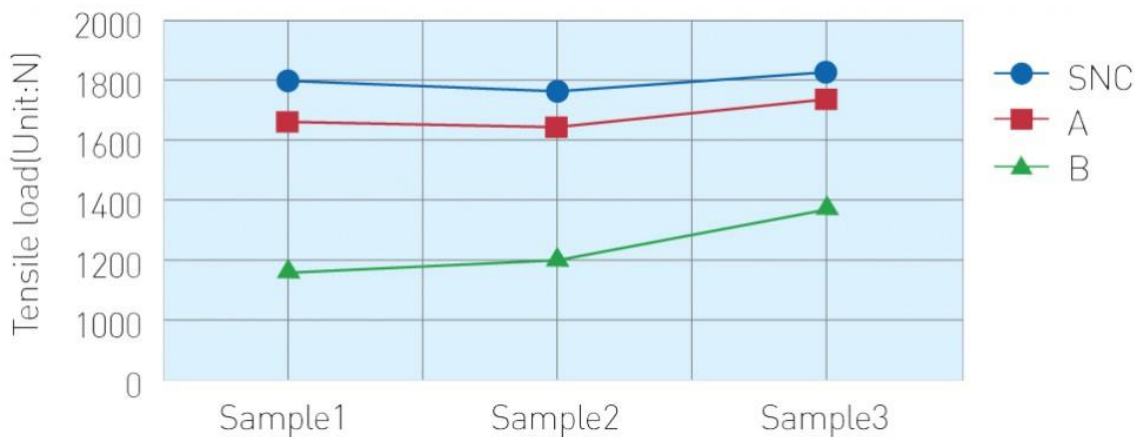

MAXIMUM TORQUE FIGURES

The Maximum torque values for Twistloc threads are as follows:

Thread	Size	Maximum Torque
Plastic	1/2"	3.5Nm
	3/4"	4Nm
	1"	5Nm

*1Nm=8.85lbf·in/1lbf·in=0.01kgf·m

END STOP

If necessary Twistloc end-stops provide either a temporary or permanent leak-free seal to a plumbing system. End Stops can also be easily removed to allow for system extensions and re-work.

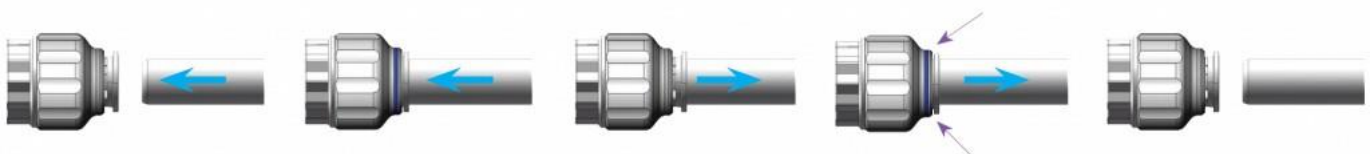

MINI MANIFOLD

For maximum flexibility, Twistloc fittings can be combined to provide multiple functions.

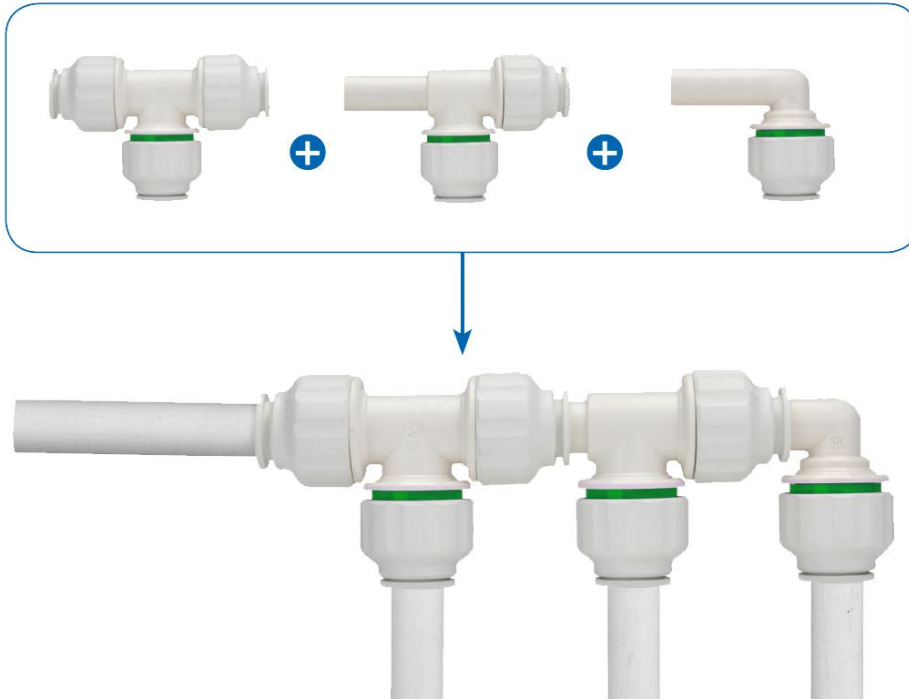

Twistloc® CAUTION

- ⚠ Do not insert fingers into Twistloc fittings as the stainless steel teeth may cause injury.
- ⚠ If Pex or PB pipe is used, then a tube insert must be used.
- ⚠ Twistloc fittings should not be used for gas, fuel, oil or compressed air applications.
- ⚠ Twistloc fittings should not be buried.
- ⚠ All Twistloc fittings and related products should be selected, installed, used and maintained in accordance with these technical specifications.
- ⚠ When cutting pipe ensure that the ends are cut square and are free from burrs.
- ⚠ Ensure there are no scratches, gouges or any form of damage on the circumference of the pipe within 1" of the cut end. Damage in this area may cause leakage. Check the fitting for any signs of damage or foreign objects.
- ⚠ Do not use damaged or scored pipe.
- ⚠ Do not use a hacksaw to cut the pipe. Do not leave burrs on the pipe.
- ⚠ Ensure that the pipe is pushed into the fitting fully and is engaged properly in accordance with Twistloc instructions
- ⚠ If the pipe is not fully inserted the connection cannot be properly sealed even if the fitting is coupled.
- ⚠ You must push the pipe into the fitting and ensure that the pipe passes through the collets (gripper) and the O ring inside the fitting.
- ⚠ When a connection has to be disassembled and reused, ensure the pipe has no damage around the circumference of the pipe. Inspect the tube and fitting for any sign of damage and ensure they are free of foreign materials. The connection can then be reassembled.

Twistloc® SYSTEM ADVANTAGES & BENEFITS

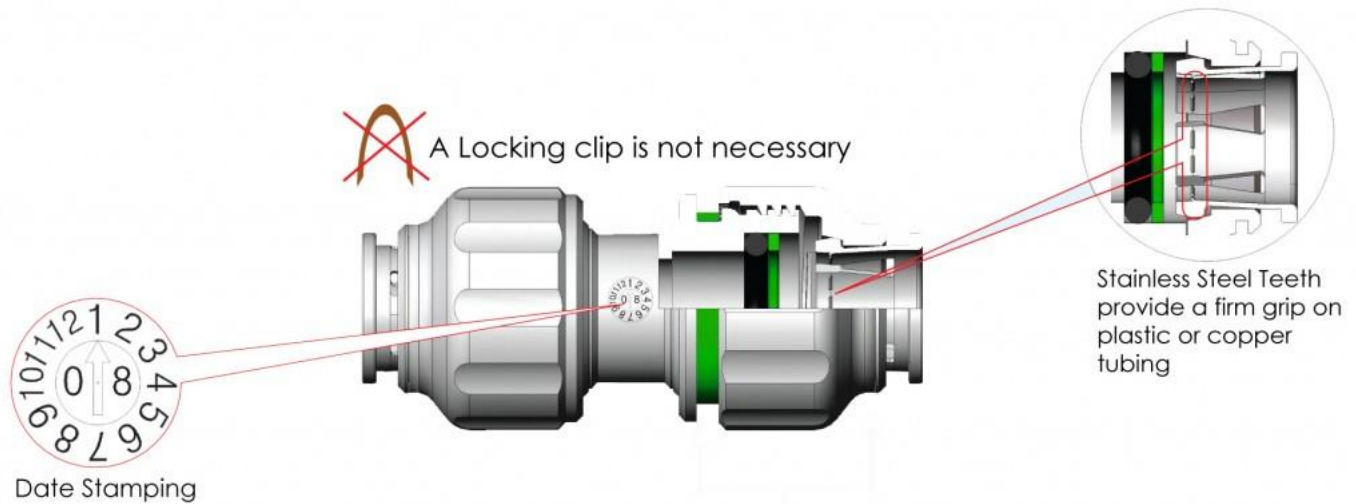

- Easy verification of collet in locked or unlocked position at a long distance
- Installation time reduced by 40%
- Removable and re-useable without damage to plumbing system or fittings.
- Lightweight for easy handling on site
- Strong gripping suitable for heating systems
- Batch tracing of all Twistloc products
- Flexibility of system enables cabling of the pipe in hard access areas
- No risk of flame or fire from use of a blowtorch
- Permanent anti-leak connection
- No corrosion
- No scale deposits
- Low heat diffusion ensures safe surface temperature
- Plumbing flexibility reduces the risk of burst under freezing temperature
- No lead, non-toxic
- No metal scrap value so of no interest to thieves
- Patented

TUBE INSERT

When using plastic pipe, the pipe manufacturer's insert must be used.

FITTINGS & VALVES PERFORMANCE

Application	Operating Temperature	Maximum Temperature	Maximum
Cold water	20°C	20°C	12 bar
Hot Water	65°C	95°C	6 bar
Central Heating	82°C	105°C	3 bar

Twistloc[®] REPAIR COUPLINGS & SLIP CONNECTORS



Cut the damaged pipe less the instructed length 'C' shown in our specification.

Connect the slip port with the pipe first and slide it until the connection is adjusted with the opposite side.



Connect to the other pipe and arrange the connection position.

Twistloc repair couplings are designed to be suitable for use on copper, PEX and PB pipe offering the installer the ability to easily repair damaged pipework.

Twistloc[®] SLIP TEE VALVE



① Cut the pipe as much as less the instructed length 'C' shown in our specification.

② Connect the slip port with the pipe first and slide it until the connection is adjusted with the opposite side.



③ Connect to the other pipe and arrange the connection position.



The Twistloc Stop Valve adaptors and Slip Tee Valves are manufactured in white Polypropylene and Polysulfone. They are designed for use in drinking water systems, American style refrigerators, ice makers, humidifiers & water filtration applications.

For our Terms and Conditions please visit our website:

www.twistloc.co.uk