



Important: Keep this document

The B32_MID domestic range of valves have been designed for the use in heating systems with both hot water cylinders and heating circuits.

CAUTION! Installation and connection should only be carried out by a qualified person and in accordance with wiring regulations.

- Do not open the products. There are no serviceable or adjustable parts inside. The system must be fused to no more than 3 Amps.
- Isolate mains supply before installation commences.
- If this equipment is installed or used in a way not specified by the manufacturer, its safety may be impaired.

TECHNICAL SPECIFICATION

MODEL	COMPRESSION	Kvs(m ³ /h)	MAX CLOSE OFF PRESSURE (BAR)	
B322MID	22 mm	7.1	1.6 (Port A)	1.2 (Port B)
B328MID	28 mm	7.6	1.2 (Port A)	0.8 (Port B)

ACTUATOR		VALVE	
Motor supply voltage	230V	Max. static pressure	21 Bar
Rated impulse voltage	2500V	Max. operating pressure	21 Bar
Power consumption	5W	Permanent operating temperature	2 ... 88°C
Max. ambient temperature	50°C		
Protection rating	IP20		
Impedance protected motor			

LEAD SUPPLIED	1.2 metre cable, 5 core. Earth Connection required.
ACTUATOR OPERATION	230V Power to open Port A - Spring return to close Port A.
	This is not a fail safe, a no fail or a safety product.
	This control is designated Type 1. AA. in accordance with EN60730.
MANUAL OVERRIDE	Type of action is multi position. Type of movement is rotary.
	Valve may be manually opened for filling or draining the system.
	In normal operation, the lever must be in the Auto position
	If the mains power is disconnected, the valve will automatically spring return to the closed position (Port A Closed) (Port B Open)

INSTALLATION & OPERATING INSTRUCTIONS

1. Valve positioning

Install the valve so the actuator head is not below the horizontal level of the pipework. The open vent and cold feed must not be isolated. The flow must be in the direction of the arrow. (from the centre port to either Port A or Port B).

2. Fitting the valve body to the pipework

Fit the valve body using the nuts and olives provided. When tightening the compression nuts ensure that only the valve body is used for grip. Take care not to overtighten.

3. Removing the actuator from the valve body

To remove the actuator head from the valve body ensure that the manual override lever is in the manual position. Loosen the screw on the side of the actuator. Remove the actuator cover. Loosen the two screws that fix the base to the valve body. Remove the actuator from the valve body.

4. Fitting the actuator to the valve body

Before fitting the actuator, please ensure that the manual override lever is in the raised manual position. The actuator is mounted by aligning the 4mm flat spindle on the valve body to the identically sized slot on the actuator. Tighten the two fixing screws on the base of the actuator. Fit the actuator cover and tighten the screw to hold the cover in place.

Once the valve is fitted, place the manual override lever in the raised manual position. It is now possible to flush and drain the system to remove any foreign matter. The system can now be refilled and corrosion inhibitor may be added if required.

Return the manual override lever to the auto position.

5. Wiring Connections for Mid position

The 1.2 metre cable can be connected as follows:

WIRE COLOUR	DESCRIPTION
Blue	Neutral supply
Orange	Hot Water ON from cylinder stat or ON from programmer Also connect to boiler and pump live.
Grey	Hot Water OFF from cylinder stat or OFF from programmer
White	Central Heating ON from room stat or ON from programmer
Yellow / Green	Earth connection

For use as a Mid position valve, see table below

ELECTRICAL CONNECTION	CABLE CONNECTION	VALVE POSITION
Not connected	Not connected	Hot Water "Port B" open.
230V connected to	Orange core	Hot Water "Port B" open.
230V connected to	Grey core	Hot Water "Port B" open.
230V connected to	White core	Mid position "Port A" and "Port B" open.
230V connected to	Grey & White cores	Central Heating "Port A" open.

6. Commissioning

Once the system has been filled and vented, ensure the manual override lever is in the auto position.

7. For Hot Water only

Switch the Central Heating **"OFF"** at the programmer or set the room thermostat to the minimum.

Switch the Hot Water **"ON"** at the programmer and set the cylinder thermostat to the maximum.

Port "B" should open on the valve.

The boiler should fire and the pump should run.

The pipe connected to Port "B" should get hot.

8. For Central Heating only

Switch the Hot Water **"OFF"** at the programmer or set the cylinder thermostat to the minimum.

Switch the Central Heating **"ON"** at the programmer and set the room thermostat to the maximum.

Port "A" should open on the valve.

The boiler should fire and the pump should run.

The pipe connected to Port "A" should get hot.

9. For Hot Water and Central Heating

Switch both the Hot Water and the Central Heating **"ON"** at the programmer.

Set both the room thermostat and the cylinder thermostat to the maximum.

The valve should go to the mid position with both Port "A" and Port "B" open.

The boiler should fire and the pump should run.

The pipes connected to Port "A" and Port "B" should get hot.

Once satisfied with the valve operation, reset the programmer and the thermostats to normal control settings.

10. Wiring Connections for Diverting

WIRE COLOUR	DESCRIPTION
Blue	Neutral supply
Grey + White	Motor ON - Port A opens
Yellow / Green	Earth connection

ELECTRICAL CONNECTION	CABLE CONNECTION	VALVE POSITION
0V connected	Grey + White core	"Port B" open. (Hot water - Normally Open)
230V connected to	Grey + White core	"Port A" open. (Heating)

CAUTION!

- Ensure the orange core is terminated safe as it will have 230V output when the Grey + White cores also have 230V.

Product Drawing B32_MID

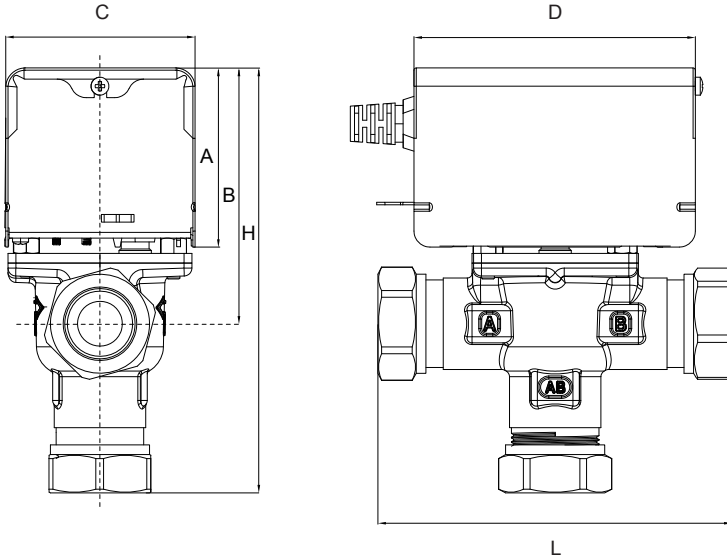

VALVE TYPE	L	H	A	B	C	D
22mm compression	111	134	56	79	60	88
28mm compression	114	136	56	79	60	88

CAUTION!

- Ensure that no more than a 3A fuse is used to supply all controls.
- It is not permissible to use any voltage other than 230V with this actuator.
- Electrical installation must conform with current I.E.E. regulations.
- Under no circumstances should the actuator be insulated or covered by any other material.
- Lack of ventilation will cause the actuator to heat up beyond the maximum permissible ambient temperature of 50°C.

The crossed out wheelee bin symbol on this product indicates that this product must not be disposed of in your general waste. It can be taken to your Local Authority Civic Amenity site for free or returned to your retailer for free when you are buying a replacement. Inappropriate waste handling could lead to negative effects on the environment and human health. With your cooperation you contribute to the correct disposal, reuse, recycling and recovery of the components of this product and the protection of the environment.



EPH Controls IE

021 471 8440
 technical@ephcontrols.com
 www.ephcontrols.com
 Cork, T12 F753

EPH Controls UK

01933 322 072
 technical@ephcontrols.co.uk
 www.ephcontrols.co.uk
 Harrow, HA1 1BD